

DN	3 x 6	SW	
15	3 x 1"	10	21
20	3 x 1"	10	21
25	3 x 1 1/4"	10	21

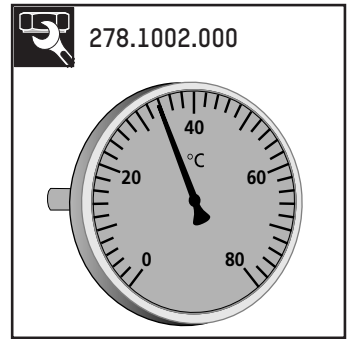

MT 52	TB	PB	
252.6003.____	100°C	10 bar	
252.6004.____	100°C	10 bar	
252.6023.____	80°C	10 bar	
252.6024.____	80°C	10 bar	
252.6034.107	90°C	10 bar	
252.6043.104	100°C	10 bar	

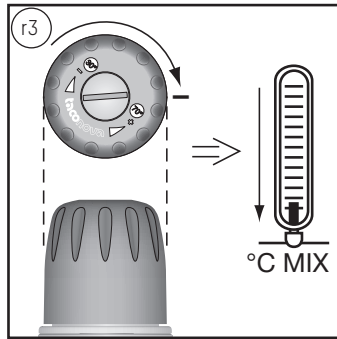

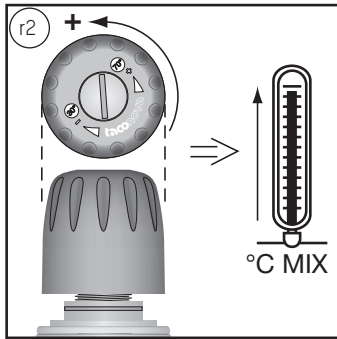
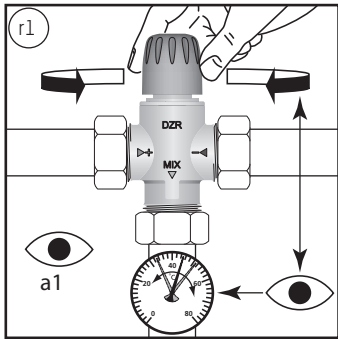
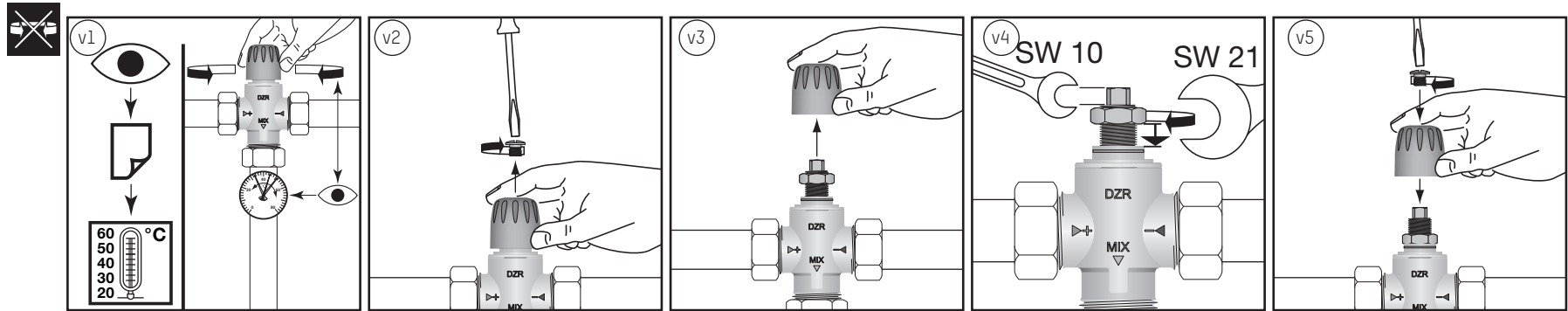

NovaMix Standard
1" | DN 15 / DN 20

298.5262.000 (30 – 70°C)
– 252.6003.104
– 252.6003.330
– 252.6043.104

298.5263.000 (20 – 40°C)
– 252.6023.104

298.5264.109 (30 – 70°C SD)

296.5203.003
2x \Rightarrow

210.5330.008 (DZR)
3x G1"– Cu ø15

210.5331.004
3x G1"– Cu ø18

210.5332.008 (DZR)
3x G1"– Cu ø22

210.6631.004
3x G1"– R½"

210.6632.004
3x G1"– R¾"

G G
Cu ø R

NovaMix Standard
1¼" | DN 25

298.5262.000 (30 – 70°C)
– 252.6004.104

298.5263.000 (20 – 40°C)
– 252.6024.104

298.5264.109 (30 – 70°C SD)
– 252.6004.107

\Rightarrow **296.5204.003**
2x

b) a) b) a)

a) **210.5333.004**
3x G1¼"–Cu ø22

b) **210.5334.004**
3x G1¼"–Cu ø28

G G
Cu ø R

210.6633.004
3x G1¼"–R1"

NovaMix High Capacity
1¼" | DN 25

298.5268.000 (20 – 70°C HC)
– 252.6034.107

296.5205.003 (incl. \Rightarrow)
2x G1¼"–R1"

210.5333.004
3x G1¼"–Cu ø22

210.5334.004
3x G1¼"–Cu ø28

210.6633.004
3x G1¼"–R1"

G G
Cu ø R